



Installation Instructions for NAA's Holster Grip for NAA Magnum Mini-Revolvers

Parts List:

1. Holster Grip Body
2. Belt Clip
3. NAA Logo
4. Left Inner Grip Panel
5. Right Inner Grip Panel
6. Two hex head screws
7. Two detentes
8. One detentes spring
9. Axle pin

Steps to Install:

1. This holster grip is equipped with a belt clip that can be installed on the left or right sides for left or right handed carry. Assemble the belt clip (#2) first through the elongate hole on one side of the holster grip body (#1) then install the NAA Logo (#3) on the opposite side from the belt clip.

2. Remove the old grips from the NAA Mini-Revolver.

3. Insert the left (#4) and right (#5) inner grip panels on the NAA Mini-Revolver frame.

4. Insert the two detentes (#7) with the detentes spring (#8) between them through the larger holes in the left (#4) and right (#5) inner grip panels.

5. Hold the detentes (#7) as you slide the holster grip over the left (#4) and right (#5) inner grip panels and onto the gun by inserting the butt of the gun frame into the holster grip body (#1) first. Maneuver the gun frame until the detentes snap into recessed holes on the holster grip body (#1). Leave the holster grip in the open position.

6. Take the axle pin (#9) and one hex head screw (#6) - screw the hex head screw into the axle pin in a clockwise direction.

7. Insert the axle pin through the holster grip body and the left (#4) and right (#5) inner grip panels .

8. Screw the remaining hex head screw (#6) into the axle pin (#9) to secure the holster grip to the frame.

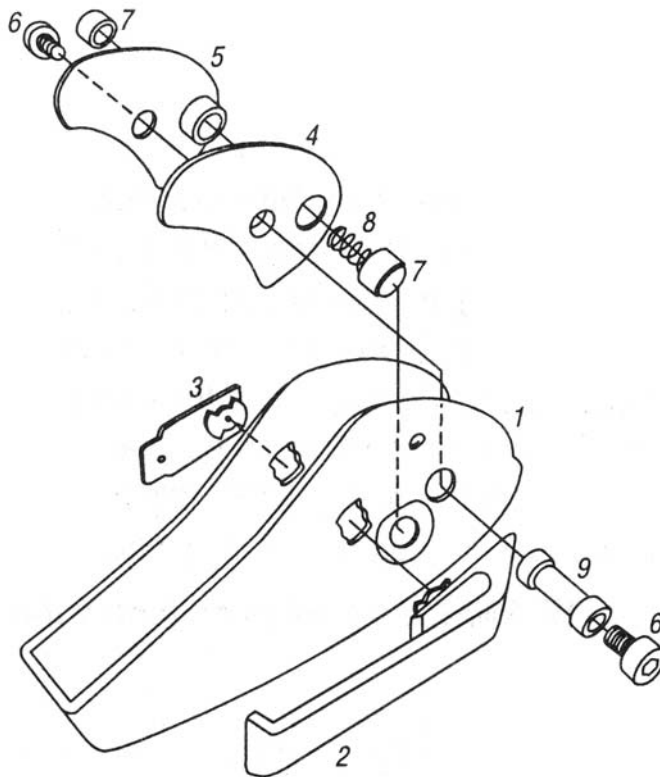

**NOTE: Do not over tighten screws!
Over tightening will not tighten grip hold on gun frame,
but will result in thread damage to the Holster Grip!**

North American Arms, Inc.
2150 South 950 East
Provo, UT 84606-6285
(801) 374-9990 or (800) 821-5783